

# Protection of Catalytic Reformers through Ceramic Moisture Sensor Measurement

## Application Background

In catalytic reforming processes used for the refining of petroleum products, heavy naphtha hydrocarbon mixes are chemically converted into high-octane liquids called reformates, which are components of petrol. A catalytic reformer operates by vaporising a mixture of naphtha and hydrogen, heating it to around 500°C and passing it into a reactor and over a bed of Platinum based catalyst. The vapour passes through two more reactors before being cooled and separated into its new constituents. Hydrogen mixing is essential to the main reactions in the reforming process.

The control of moisture content in hydrogen recycled gas is critical to ensure the efficient operation of the plant. It is desirable for the benefit of the catalytic reactions to maintain the moisture level within the 10 to 20ppm<sub>v</sub> range. If the moisture level decreases below this level, the catalyst will deteriorate, causing a loss of productivity. High moisture content will remove chloride from the catalyst, accelerating catalytic activity loss to the point whereby high octane levels can no longer be achieved. The effects of both these scenarios will result in the catalyst requiring replacement much more frequently than otherwise necessary, and it is extremely costly to replace. Hydrochloric acid is periodically injected into the process gas stream, to recondition and re-activate the catalyst.



Sasol Refinery, South Africa

## Measurement Technique

Using the Michell Ceramic Moisture Sensor, the Easidew Pro IS can be installed in a simple sampling system made from high quality stainless steel components. During the regeneration phase the sensor should be isolated from the process gas sample to avoid corrosion problems caused by this HCL and the coinciding increase in moisture concentration up to 2000ppm<sub>v</sub> or more. The arrangement of the sampling system should include valves on both inlet and outlet to facilitate this by shutting the sensor off from the process gas stream, and temporarily supplying it with instrument air.

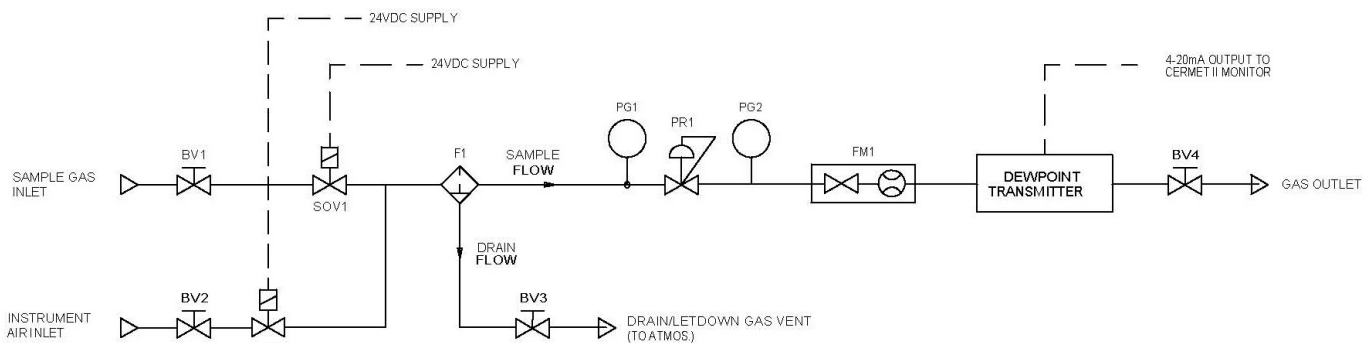

Typical Promet Sampling System Arrangement

If a remote or local display with alarms is required then the Easidew Online monitor can be installed with this system. The Sensor can be installed at full process pressure to indicate either dew-point temperature or moisture content in ppm<sub>v</sub> under actual line conditions. Output units must be specified when ordering.

## Reference Users

BP Oil, BP Research, ELF Oil, Exxon Chemicals, IFP, Mobil Oil



0179

### **Michell Instruments**

48 Lancaster Way Business Park  
Ely Cambridgeshire  
CB6 3NW

Tel: +44 1353 658000

Fax: +44 1353 658199

Email: [info@michell.com](mailto:info@michell.com)

Web: [www.michell.com](http://www.michell.com)



Q06284