

XTC601 Binary Gas Analyzer

Thermal Conductivity Technology in Safe or Hazardous Areas

A robust, linear and stable thermal conductivity analyzer for measurement of binary gas mixes such as air in hydrogen, nitrogen, argon, helium or carbon-dioxide. The sensor is housed in a rugged casing, making it suitable for a wide range of applications. The analyzer can be supplied explosion-proof and suitable for hazardous areas.



Highlights

- Suitable for use in ATEX, IECEx, TC TR Ex & cCSAus
- Optional light guide following NAMUR standard
- Compact and rugged design with an EExd enclosure and two off 4–20 mA output
- Touch-screen display allows calibration or adjustment without the need for a hot works permit
- Accuracy of better than $\pm 2\%$ full scale
- IP66 rated enclosure
- Low cost of ownership due to minimal maintenance
- Ranges available: 0–5 up to 0–100%, 0–1% for H₂ or He
- Stability $\pm 0.5\%$ per month (of span)

Applications

- Hydrogen coolant in electricity turbines
- Product quality in air separation plants
- Syngas production
- Helium recovery
- Fuel cell research
- Product quality such as air in argon for double glazing



Biogas Plant

Michell XTC601 Thermal Conductivity Analyzer for Safe or Hazardous Areas

The XTC601 Binary Gas Analyzer is designed to measure the percentage of a selected gas in a binary mix. Using thermal conductivity with high quality thermistors, the sensor is reliable and highly stable. The analyzer is housed in an explosion-proof case and is rated ATEX Cat II for use in hazardous areas. For installation in non-hazardous areas, a general purpose version is available.

Features

High Sensor-Stability Reduces Calibration Costs

The sensor in Michell's XTC601 Binary Gas Analyzer largely eliminates drift associated with other comparable devices, improving the stability of the measurement. This allows longer calibration intervals and reduces both labor and consumable costs.

Reliable Long-Term Performance

The thermal conductivity sensor has no moving parts, and is therefore not affected by vibration or movement. This makes it suitable for offshore and similar installations.

Non-Depleting Technology

The non-depleting sensor technology means that there is no regular replacement of cells, thus greatly reducing maintenance time and the cost of ownership. The cell performance is consistent and does not drift as it is not consumed by the process.

Easy Installation with Local Display

The XTC601 Binary Gas Analyzer provides two 4–20 mA outputs and is housed in a robust and weather-proof casing, allowing the analyzer to be placed at the point of measurement.

The closer the analyzer can be installed to the sample point, the better, for many reasons. These include, faster overall speed of response (for safety), less sample line or cabling (saves cost) greater choice of installation points (flexibility). Having a local display does not require two operators (or walking back and forth to the control room) for maintenance or diagnostics.

External Sensor Input

The unit has the facility to accept a 4–20 mA signal from an external source such as dew-point sensor, temperature probe or user-defined sensor, and display it on the screen. This saves the cost of buying and installing an external display for another parameter that only requires occasional visual inspection.

Technology

Thermal Conductivity Sensor

Thermal conductivity (TC) is a property of all gases. This can be exploited as each gas has a different TC value and is used to determine the level of one gas in a binary or pseudo-binary mix. Air is a good example of a pseudo-binary mix as it has a fixed proportion of oxygen and nitrogen (both with very similar thermal conductivities). The analyzer can be supplied with a fixed or flowing reference.

The XTC601 Binary Gas Analyzer utilizes thermal conductivity technology to accurately measure one of the two gases present in the sample. The instrument is very stable which gives the user confidence in the measurement. This is important in safety applications such as CO₂/H₂ membrane monitoring.

Measurement Principle

The measuring principle is via matched thermistors in a Wheatstone Bridge configuration. One thermistor is in the sample cell and the other is either in a sealed (or flowing) reference chamber. The whole assembly is heated to +50°C to ensure an iso-thermal environment. This provides an accurate and stable platform for measuring the target gas concentration.

Flexible Packaging

The XTC601 binary gas analyzer is suitable for Safe (GP) or Hazardous (EX) Area classification depending on the individual customer's needs. This allows the user to determine the price to feature ratio that best suits each installation.



XTC601 (EX1 or GP1)
The analyzer provides a local HMI for the user to access all the functions of the analyzer through the glass via capacitance buttons. As well as displaying the target gas concentration, there is a status bar showing messages. The user can scroll through the front screens to see a graph of the latest period (user defined), min and max values, reading from an external sensor and alarm history.



XTC601 (GP2)
GP2 is fitted with flame arrestors for use with flammable samples in a safe area.



XTC601 (EX3 or GP3)
The basic model is a binary gas analyzer that provides 4-20 mA outputs, alarm relays & RS485 serial communications. There is application software included that allows the user to visualize and interact with the unit from their PC or control system. There is an optional light guide that will indicate that the unit is powered up and/or in alarm condition.



Application Software
The XTC601 binary gas analyzer is supplied with application software that will allow the user remote access to the unit. This includes displaying the target gas concentration, alarms, graphs, changing parameters and even remote calibration.

PS601 Sample Handling System for the XTC601

For a long, trouble-free life, analyzers invariably require a clean, dry gas that is free from particulates and at a suitable temperature and pressure. In the real world, the process gas to be measured almost never fulfils these requirements. Michell Instruments offers a complete solution for this problem: The XTC601 and PS601 Sample Handling System. This modular system is constructed in consultation with customers to ensure the best possible solution for each individual application.

Flow Schematic for CO₂ in Bio Gas

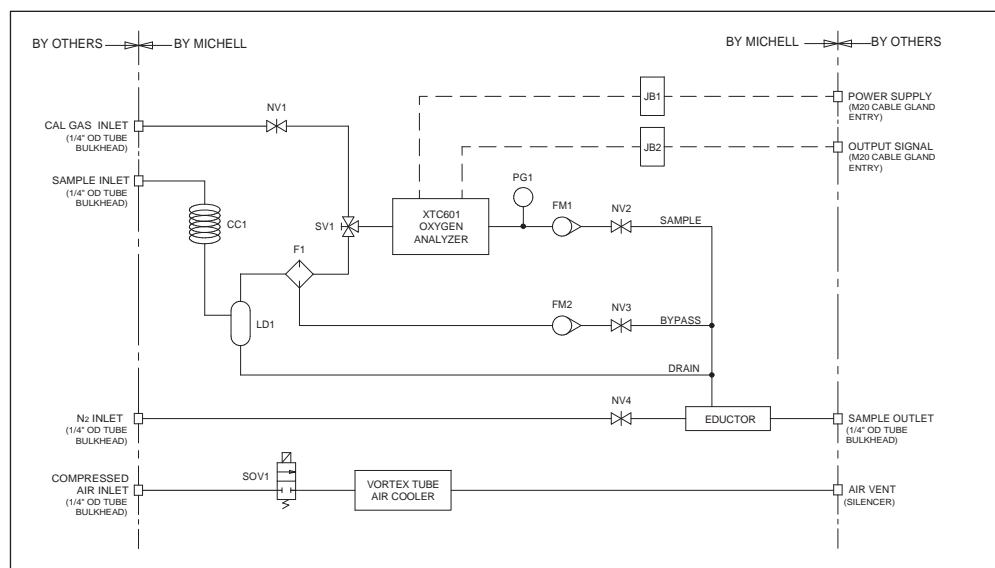

The sampling system shown is for use with "misty" gases sampled in a hazardous area. It is one of the more complex sampling systems available.

The use of an eductor negates the issues of using a pump with hydrocarbons and reduces cost. There is also a vortex cooler to keep the system cabinet cool.

Technical Specifications

Performance	
Measurement technology	Thermal Conductivity sensor
Measured gases	Air, Ar, CH ₄ , CO ₂ , H ₂ , He, or N ₂
Gas requirements	Non-condensing sample with particles <3µm
Measurement range	Selectable from 0–5% up to 0–100% 50–100% up to 90–100%
Measurement range (H ₂ & He)	Selectable from 0–1% up to 0–100% 50–100% up to 99–100%*
Display resolution	0.1%
Display type	Backlit LCD
Intrinsic error (accuracy)	< ±2% of span**
Response time (T90)	Standard < 20 seconds**
Repeatability	±0.2% of span
Linearity	±1% span
Zero stability	±0.5% of span per month
Span stability	±0.5% of span per month
Sample flow rate	100 to 500 ml/min (0.2 to 1.27 scfh)
Sample Flow Rate (Ex)	270 to 330 ml/min (0.54 to 0.66 scfh)
Sample flow effect (calibrated at 300 ml/min)	< 1% of span for flows: 100 to 500 ml/min
Sample pressure	Analyzers are calibrated at atmospheric pressure and must be operated with an atmospheric vent, unless otherwise stated.
Maximum Safe Pressure	4 barg (58 psig)
Sample temperature	5 to 45°C (+32 to +104°F) max
Sample cell temperature	+50°C (+122°F)
Electrical Specifications	
Analog inputs	2 off 4–20 mA inputs One for an external sensor that can be displayed on the screen One to act as an active compensation for the process conditions
Analog outputs	2 off 4–20 mA outputs
Output ranges	Primary range is set to the calibrated range of the instrument The second is user-selectable
Alarms	2 off single pole changeover (SPCO) relays for concentration (250 V, 5 A max)
Datalogging	The user can use the digital communications to log the output from the analyzer, the unit will store 40 alarm points and the min/max concentrations with date and time stamp
Digital communications	Modbus RTU over RS485 Protocol
Power supply	24 V DC, 1.5 A max

*Ranges 98-100% and 99-100% (for H₂ and HE only) will require a flowing reference and selection of the 4-port model.

**The typical intrinsic error and response time will be as above. Certain gas combinations and/or ranges may have different specifications. Please consult Michell Instruments for specific cases. For example, CO₂ / N₂ would be < 50 seconds for T90.

Note: If the 4-port version is selected then a reference gas with a flow rate of 300ml/min is required

Operating Conditions	
Ambient temperature	0 to 40°C (32 to 104°F)
Mechanical Specifications	
Warm up time	< 25 minutes
Stabilization time	5 minutes
Dimensions	234 x 234 x 172mm (w x d x h)
Weight	9.7 kg
Wetted materials	316 stainless steel, borosilicate glass, platinum, (plus O-ring)
O-Ring materials	Viton, Silicone or Ekraz
Gas connection	1/4" NPT Female GP models 1/8" NPT Female Ex & GP2 models
Ingress protection	IP66, NEMA 4
Hazardous Area Classification	
ATEX	II 2GD Ex d IIB +H2 T6 Gb Ex tb IIIC T85°C Db IP66
IECEX	Ex d IIB +H2 T6 Gb Ex tb IIIC T85°C Db IP66
Storage Temperature by O-ring type	Silicon: Ta O-ring = -40°C to +55°C Viton: Ta O-ring = -15°C to +55°C Ekraz: Ta O-ring = -10°C to +55°C
cCSAus	Class I, Division 1, Groups B,C,D T6
TC TR Ex	1Ex d IIB+H2 T6 Gb

Dimensions

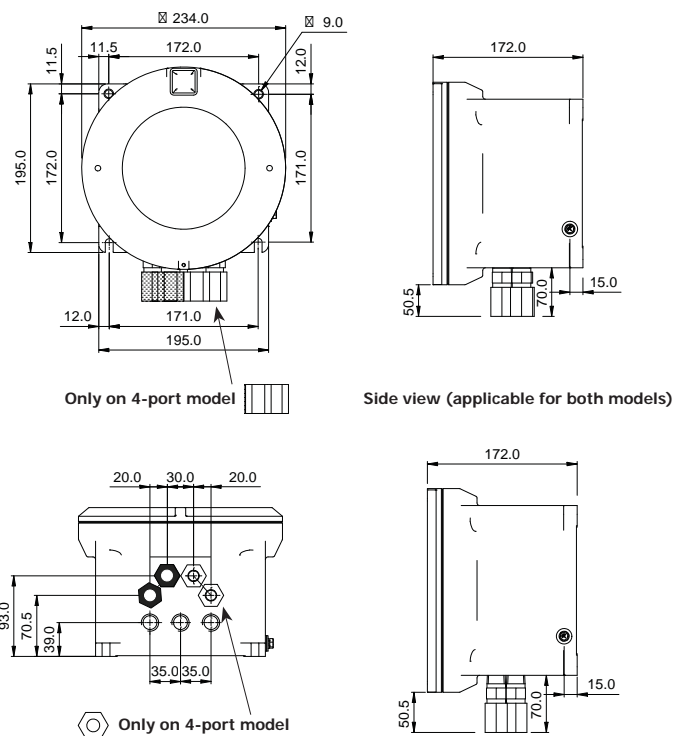

Michell Instruments Ltd 48 Lancaster Way Business Park, Ely, Cambridgeshire, CB6 3NW
Tel: +44 (0) 1353 658000, Fax: +44 (0) 1353 658199, Email: uk.info@michell.com, Web: www.michell.com/uk

Michell Instruments adopts a continuous development programme which sometimes necessitates specification changes without notice.
Issue no: XTC601_97440_V4_UK_0718