



Background

Investment in alternative fuel technologies for motor vehicles continues to gather pace, as commercial viability becomes a reality. One of the leading technologies is fuel cells which represents a huge step forward in fundamental technology (even though it has been in existence for at least fifty years). Moisture plays an important part in determining efficiency, quality and safety issues relating to delivery and performance of the technologies.

"I believe fuel cell vehicles will finally end the hundred-year reign of the internal combustion engine as the dominant source of power for personal transportation. It's going to be a winning situation all the way around - consumers will get an efficient power source, communities will get zero emissions, and automakers will get another major business opportunity - a growth opportunity." William C. Ford, Jr., Ford Chairman, International Auto Show, January 2000.

Every major auto manufacturer has been researching and developing some type of fuel cell vehicle. Projections made by car companies themselves and energy and automotive experts concur that around 2010, and perhaps earlier, car manufacturers will have mass production capabilities for fuel cell vehicles, signifying the time they would be economically available to the average consumer.

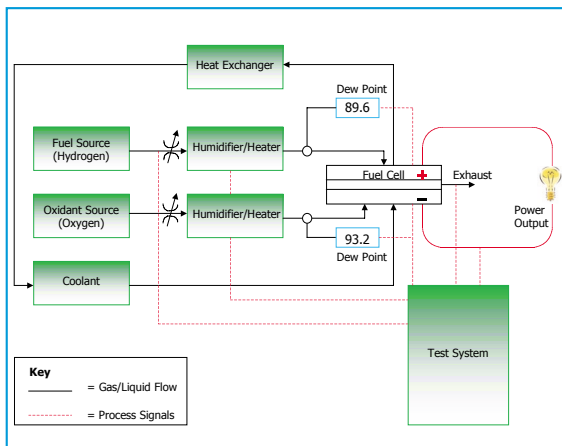

PEM fuel cell test station layout

The Technology

There are several different types of fuel cell. Because of its low operating temperature the fuel cell used to power motor vehicles is the Proton Exchange/ Polymer Electrolyte Membrane (PEM) fuel cell. In principle, a fuel cell operates like a battery. Unlike a battery, a fuel cell does not run down or require recharging. It will produce energy in the form of electricity and heat as long as fuel is supplied.

A fuel cell consists of two electrodes sandwiched around an electrolyte. Oxygen passes over one electrode and hydrogen over the other, generating electricity, water and heat.

Hydrogen fuel is fed into the "anode" of the fuel cell. Oxygen (or air) enters the fuel cell through the cathode. Encouraged by a catalyst, the hydrogen atom splits into a proton and an electron, which take different paths to the cathode. The proton passes through the electrolyte. The electrons create a separate current that can be utilized before they return to the cathode, to be reunited with the hydrogen and oxygen in a molecule of water.

A fuel cell system which includes a "fuel reformer" can utilise the hydrogen from any hydrocarbon fuel - from natural gas to methanol, and even gasoline. Since the fuel cell relies on chemistry and not combustion, emissions from this type of a system would still be much smaller than emissions from the cleanest fuel combustion processes.

Typical process efficiency of 80% can be achieved, which is more than double that of an internal combustion engine.

Moisture Measurement

High moisture content within the hydrogen fuel yields greater process efficiency. This is related to the effectiveness of the catalytic action of splitting the hydrogen molecule into two hydrogen ions and two electrons - the driver of the process. It is clear in any case that in both the development of fuel cells, with complex and sophisticated fuel cell test stations; and also in production fuel cells, the hydrogen must be saturated with moisture at temperatures up to 80 - 90 °C to gain best performance. Hence the need, in the development phase, for accurate and reliable measurement of hydrogen gas dew point within the process. Many developers benefit from using Michell Instruments' Optidew Cooled Mirror Hygrometer with High Temperature sensor for these determinations. Once optimum operating conditions for the particular fuel cell have been determined, the production units can be built with an appropriate humidifier for the hydrogen fuel.

Fuel Cell technologies hold promise for a greener future in the automotive industry and Michell Instruments is in a strong position to be able to provide a humidity measurement solution to suit the applications of either industry.



High Temperature Sensor



Optidew

Reference Users

Opel, DVGW, Ballard Power, TH Aachen, Johnson Matthey